

S. JOHNSON.

METAL-TURNING LATHE.

No. 185,682.

Patented Dec. 26, 1876.

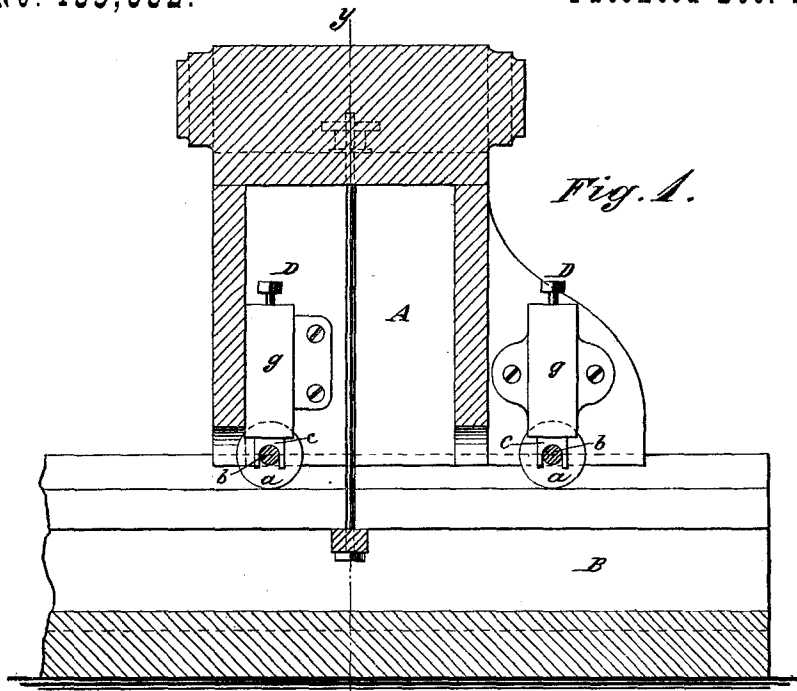

Fig. 1.

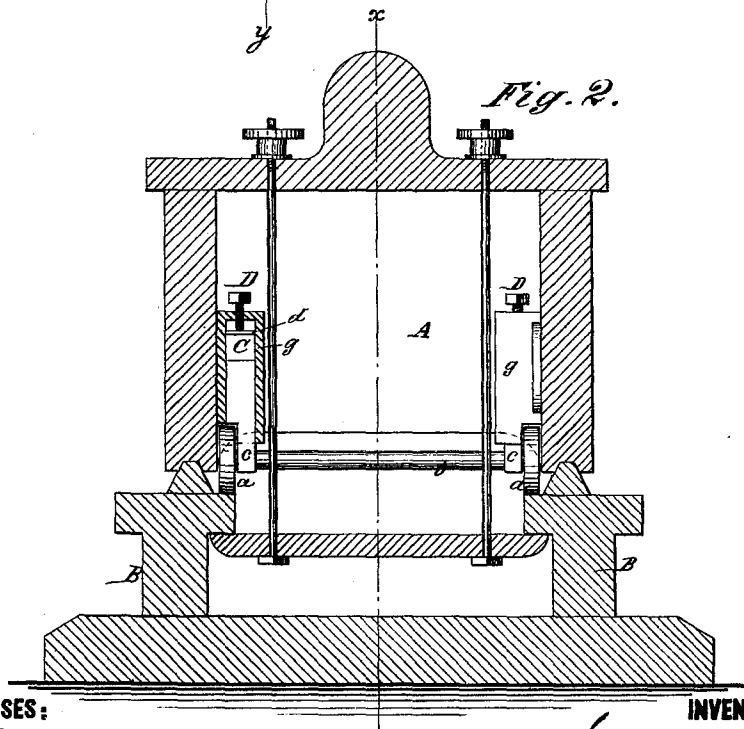

Fig. 2.

WITNESSES:

H. Rydquist.
J. A. Scarborough

INVENTOR:

Sander Johnson

BY

Munnell

ATTORNEYS.

UNITED STATES PATENT OFFICE.

SANDER JOHNSON, OF MINNEAPOLIS, MINNESOTA.

IMPROVEMENT IN METAL-TURNING LATHES.

Specification forming part of Letters Patent No. 185,682, dated December 26, 1876; application filed October 7, 1876.

To all whom it may concern:

Be it known that I, SANDER JOHNSON, of Minneapolis, in the county of Hennepin and State of Minnesota, have invented a new and Improved Attachment for Tail-Stocks for Lathes, of which the following is a specification:

Figure 1 is a longitudinal section of a tail-stock and bed of a lathe, taken on line *xx* in Fig. 2, showing my improvement. Fig. 2 is a transverse section on line *yy* in Fig. 1.

Similar letters of reference indicate corresponding parts.

My improvement consists in the combination of friction-rollers placed in spring-bearings with the tail-stock of a lathe in such a manner that they bear up the tail-stock, and thus obviate friction between it and the lathe-bed.

The object of the invention is to provide a means whereby it is made possible to easily move the tail-stock of the heaviest lathe without the use of levers or gearing.

A is an ordinary tail-stock, and B a lathe-bed. *a a* are rollers attached to the shaft *b*, and *c* are followers moving in sockets *g* that are attached to the inner surfaces of the sides of the tail-stock. The followers *c* are formed into journal-boxes at their lower ends, and rest upon the shaft *b*. C is a spring, which may be of rubber or other suitable material, that

is placed between the upper end of the follower *c* and the end of the socket *g*, and is provided with a metallic plate, *d*. D is a set-screw that passes through the upper end of the socket *g*, and bears upon the spring C. Two similar sets of friction rollers and springs are attached to the tail-stock, one set at the front, and one at the rear. These rollers run upon the lathe-bed inside of the ways. The springs in the sockets are sufficiently compressed to counterbalance the weight of the tail-stock, and nearly or quite raise it from the lathe-bed, thus relieving the friction between the stock and bed, making it an easy matter to move the heaviest tail-stock. It also obviates the necessity for oiling the ways, and thus prevents the accumulation of gum and chips, which is a common source of annoyance, and is also damaging to the latter.

Having thus described my invention, I claim as new and desire to secure by Letters Patent—

The combination of the rollers *a*, shaft *b*, follower *c*, spring C, socket *g*, set-screw D, and the ordinary tail-stock of a lathe, substantially as shown and described.

SANDER JOHNSON.

Witnesses:

C. G. GOODRICH, Jr.,
W. E. MOORE.